

ELECTROMAGNETIC TRAPS FOR CHARGED AND NEUTRAL PARTICLES

Nobel Lecture, December 8, 1989

by

WOLFGANG PAUL

Physikalisches Institut der Universität Bonn, Nussallee 12, D-5300 Bonn, F.R.G.

Experimental physics is the art of observing the structure of matter and of detecting the dynamic processes within it. But in order to understand the extremely complicated behaviour of natural processes as an interplay of a few constituents governed by as few as possible fundamental forces and laws, one has to measure the properties of the relevant constituents and their interaction as precisely as possible. And as all processes in nature are interwoven one must separate and study them individually. It is the skill of the experimentalist to carry out clear experiments in order to get answers to his questions undisturbed by undesired effects and it is his ingenuity to improve the art of measuring to ever higher precision. There are many examples in physics showing that higher precision revealed new phenomena, inspired new ideas or confirmed or dethroned well established theories. On the other hand new experimental techniques conceived to answer special questions in one field of physics became very fruitful in other fields too, be it in chemistry, biology or engineering. In awarding the Nobel prize to my colleagues Norman Ramsey, Hans Dehmelt and me for new experimental methods the Swedish Academy indicates her appreciation for the aphorism the Göttingen physicist Georg Christoph Lichtenberg wrote two hundred years ago in his notebook "one has to do something new in order to see something new". On the same page Lichtenberg said: "I think it is a sad situation in all our chemistry that we are unable to suspend the constituents of matter free".

Today the subject of my lecture will be the suspension of such constituents of matter or in other words, about traps for free charged and neutral particles without material walls. Such traps permit the observation of isolated particles, even of a single one, over a long period of time and therefore according to Heisenberg's uncertainty principle enable us to measure their properties with extremely high accuracy.

In particular, the possibility to observe individual trapped particles opens up a new dimension in atomic measurements. Until few years ago all measurements were performed on an ensemble of particles. Therefore, the measured value - for example, the transition probability between two eigenstates of an atom - is a value averaged over many particles. Tacitly

one assumes that all atoms show exactly the same statistical behaviour if one attributes the result to the single atom. On a trapped single atom, however, one can observe its interaction with a radiation field and its own statistical behaviour alone.

The idea of building traps grew out of molecular beam physics, mass spectrometry and particle accelerator physics I was involved in during the first decade of my career as a physicist more than 30 years ago. In these years (1950 - 55) we had learned that plane electric and magnetic multipole fields are able to focus particles in two dimensions acting on the magnetic or electric dipole moment of the particles. Lenses for atomic and molecular beams [1,2,3] were conceived and realized improving considerably the molecular beam method for spectroscopy or for state selection. The lenses found application as well to the ammonia as to the hydrogen maser [4].

The question "What happens if one injects charged particles, ions or electrons, in such multipole fields" led to the development of the linear quadrupole mass spectrometer. It employs not only the focusing and defocusing forces of a high frequency electric quadrupole field acting on ions but also exploits the stability properties of their equations of motion in analogy to the principle of strong focusing for accelerators which had just been conceived.

If one extends the rules of two-dimensional focusing to three dimensions one possesses all ingredients for particle traps.

As already mentioned the physics or the particle dynamics in such focusing devices is very closely related to that of accelerators or storage rings for nuclear or particle physics. In fact, multipole fields were used in molecular beam physics first. But the two fields have complementary goals: the storage of particles, even of a single one, of extremely low energy down to the micro-electron volt region on the one side, and of as many as possible of extremely high energy on the other. Today we will deal with the low energy part. At first I will talk about the physics of dynamic stabilization of ions in two- and three-dimensional radio frequency quadrupole fields, the quadrupole mass spectrometer and the ion trap. In a second part I shall report on trapping of neutral particles with emphasis on an experiment with magnetically stored neutrons.

As in most cases in physics, especially in experimental physics, the achievements are not the achievements of a single person, even if he contributed in posing the problems and the basic ideas in solving them. All the experiments I am awarded for were done together with research students or young colleagues in mutual inspiration. In particular, I have to mention H. Friedburg and H. G. Bennewitz, C.H. Schlier and P. Toschek in the field of molecular beam physics, and in conceiving and realizing the linear quadrupole spectrometer and the r.f. ion trap H. Steinwedel, O. Osberghaus and especially the late Erhard Fischer. Later H.P. Reinhard, U. v. Zahn and F. v. Busch played an important role in developing this field.

Focusing and Trapping of particles

What are the principles of focusing and trapping particles? Particles are elastically bound to an axis or a coordinate in space if a binding force acts on them which increases linearly with their distance r

$$F = -cr.$$

In other words if they move in a parabolic potential

$$\Phi \sim (ax^2 + \beta y^2 + \gamma z^2)$$

The tools appropriate to generate such fields of force to bind charged particles or neutrals with a dipole moment are electric or magnetic multipole fields. In such configurations the field strength, or the potential respectively increases according to a power law and shows the desired symmetry. Generally if m is the number of "poles" or the order of symmetry the potential is given by

$$\Phi \sim r^{m/1} \cos(m/2 \cdot \varphi).$$

For a quadrupole $m = 4$ it gives $\Phi \sim r^2 \cos 2\varphi$, and for a sextupole $m = 6$ one gets $\Phi \sim r^3 \cos 3\varphi$ corresponding to a field strength increasing with r and r^2 respectively.

Trapping of charged particles in 2- and J-dimensional quadrupole fields

In the electric quadrupole field the potential is quadratic in the Cartesian coordinates.

$$\Phi = \frac{\Phi_0}{2r^2} (ax^2 + \beta y^2 + \gamma z^2) \tag{1}$$

The Laplace condition $\Delta\Phi = 0$ imposes the condition $\alpha + \beta + \gamma = 0$. There are two simple ways to satisfy this condition.

a) $a = 1 = -\gamma, \beta=0$ results in the two-dimensional field

$$\Phi = \frac{\Phi_0}{2r_0^2} (x^2 - z^2) \tag{2}$$

b) $a = \beta = 1, \gamma = -2$ generates the three-dimensional configuration, in cylindrical coordinates

$$\Phi = \frac{\Phi_0(r^2 - 2z^2)}{r_0^2 + 2z_0^2} \text{ with } 2z_0^2 = r_0^2. \tag{3}$$

The two-dimensional quadrupole or the mass filter [5,6]

Configuration a) is generated by 4 hyperbolically shaped electrodes linearly extended in the y -direction as is shown in Fig. 1. The potential on the electrodes is $\pm\Phi_0/2$ if one applies the voltage Φ_0 between the electrode pairs. The field strength is given by

$$E_x = -\Phi_0/r_0^2 \cdot x \quad , \quad E_z = \Phi_0/r_0^2 \cdot z \quad , \quad E_y = 0$$

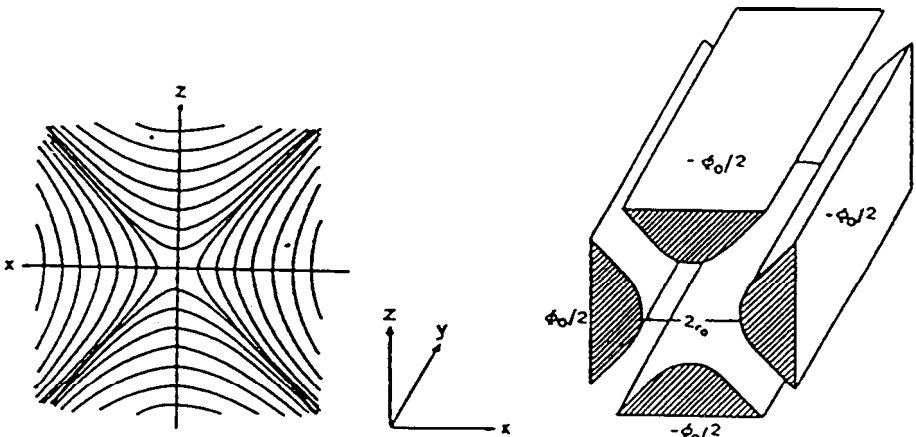

Figure I. a) Equipotential lines for a plane quadrupole field, b) the electrodes Structure for the mass filter.

If one injects ions in the y -direction it is obvious that for a constant voltage Φ_0 the ions will perform harmonic oscillations in the x - y -plane but due to the opposite sign in the field E_z their amplitude in the z -direction will increase exponentially. The particles are defocused and will be lost by hitting the electrodes.

This behaviour can be avoided if the applied voltage is periodic. Due to the periodic change of the sign of the electric force one gets focusing and defocusing in both the x - and z -directions alternating in time. If the applied voltage is given by a dc voltage U plus an r.f. voltage V with the driving frequency ω

$$\Phi_0 = U + V \cos \omega t$$

the equations of motion are

$$\begin{aligned} \ddot{x} + \frac{e}{mr_0^2} (U + V \cos \omega t) x &= 0 \\ \ddot{z} - \frac{e}{mr_0^2} (U + V \cos \omega t) z &= 0 \end{aligned} \quad (4)$$

At first sight one expects that the time-dependent term of the force cancels out in the time average. But this would be true only in a homogenous field. In a periodic inhomogenous field, like the quadrupole field there is a small average force left, which is always in the direction of the lower field, in our case toward the center. Therefore, certain conditions exist that enable the ions to traverse the quadrupole field without hitting the electrodes, i.e. their motion around the y -axis is stable with limited amplitudes in x - and z -directions. We learned these rules from the theory of the Mathieu equations, as this type of differential equation is called.

In dimensionless parameters these equations are written

$$\begin{aligned} \frac{d^2 x}{d\tau^2} + (a_x + 2q_x \cos 2\tau) x &= 0 \\ \frac{d^2 z}{d\tau^2} + (a_z + 2q_z \cos 2\tau) z &= 0 \end{aligned} \quad (5)$$

By comparison with equation (4) one gets

$$a_x = -a_z = \frac{4eU}{mr_0^2\omega^2}, \quad q_x = -q_z = \frac{2eV}{mr_0^2\omega^2}, \quad \tau = \frac{\omega t}{2}. \quad (63)$$

The Mathieu equation has two types of solution.

1. stable motion: the particles oscillate in the x-z-plane with limited amplitudes. They pass the quadrupole field in y-direction without hitting the electrodes.

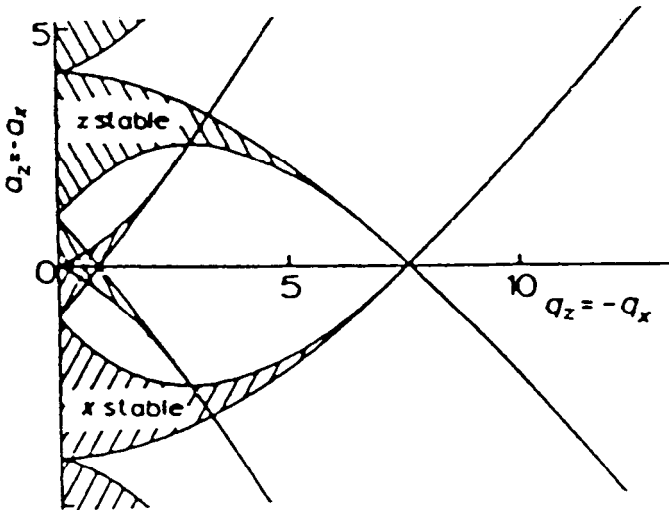

Figure 2. The overall stability diagram for the two-dimensional quadrupole field.

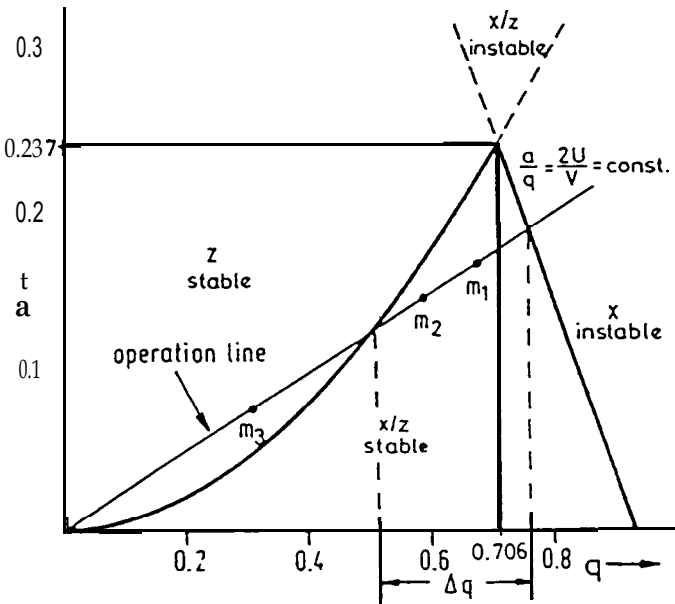

Figure 3. The lowest region for simultaneous stability in x- and z-direction. All ion masses lie on the operation line, $m_1 > m_2$.

2. unstable motion: the amplitudes grow exponentially in x , z or in both directions. The particles will be lost.

Whether stability exists depends only on the parameters a and q and not on the initial parameters of the ion motion, e.g. their velocity. Therefore, in an a - q -map there are regions of stability and instability (Fig.2). Only the overlapping region for x and z stability is of interest for our problem. The most relevant region $0 < a, q < 1$ is plotted in Fig. 3. The motion is stable in x and z only within the triangle.

For fixed values r_0, ω, U and V all ions with the same m/e have the same operating point in the stability diagram. Since a/q is equal to $2U/V$ and does not depend on m , all masses lie along the operating line $a/q = \text{const}$. On the q axis ($a = 0$, no d.c. voltage) one has stability from $0 < q < q_{\text{max}} = 0.92$ with the consequence that all masses between $\infty > m > m_{\text{min}}$ have stable orbits. In this case the quadrupole field works as a high pass mass filter. The mass range Δm becomes narrower with increasing dc voltage U i.e. with a steeper operating line and approaches $\Delta m = 0$, if the line goes through the tip of the stability region. The bandwidth in this case is given only by the fluctuation of the field parameters. If one changes U and V simultaneously and proportionally in such a way that a/q remains constant, one brings the ions of the various masses successively in the stability region scanning through the mass spectrum in this way. Thus the quadrupole works as a mass spectrometer.

A schematic view of such a mass spectrometer is given in Fig. 4. In Figs. 5a,b. the first mass spectra obtained in 1954 are shown [6]. Clearly one sees the influence of the d.c. voltage U on the resolving power.

In quite a number of these the performance and application of such

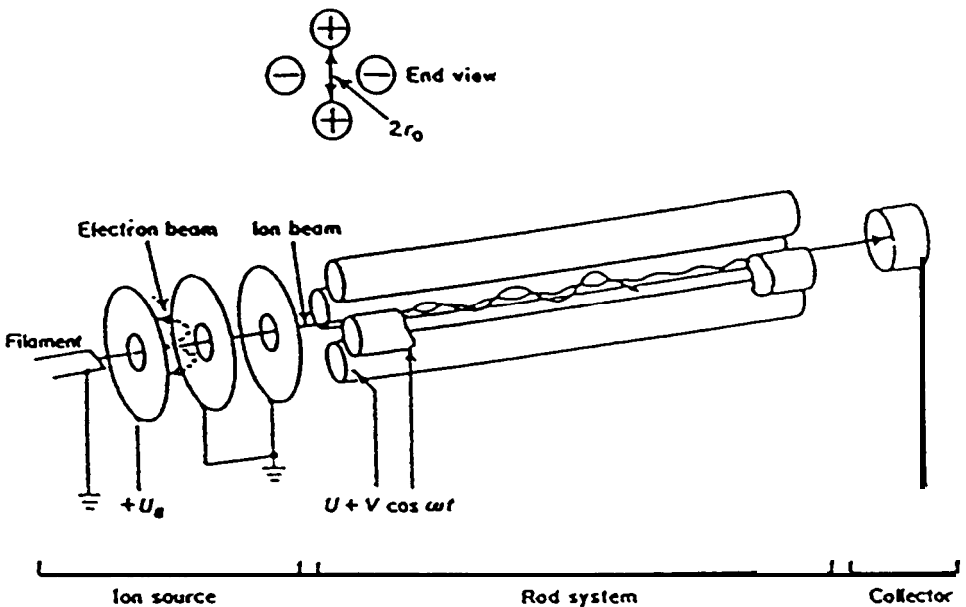

Figure 4. Schematic view of the quadrupole mass spectrometer or mass filter.

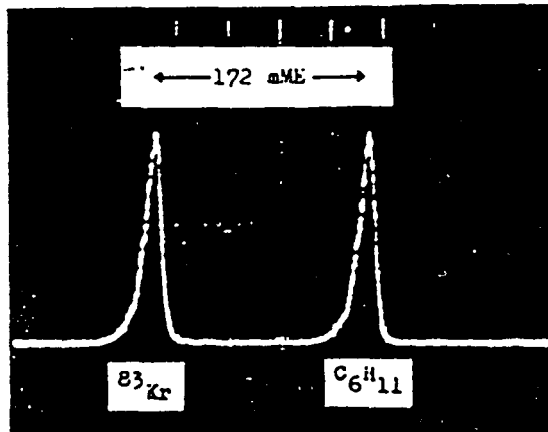
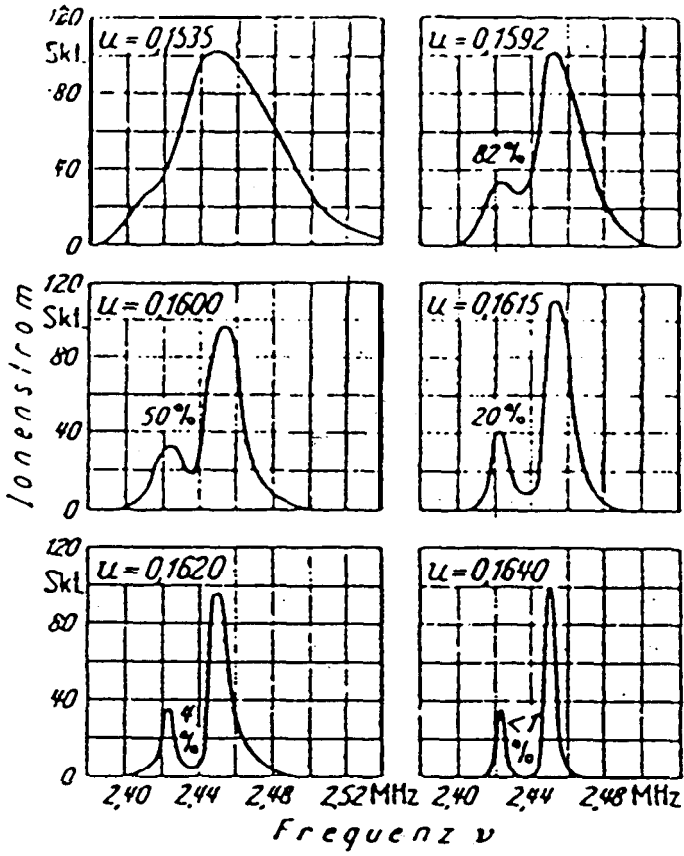

Figure 5. a) Very first mass spectrum of Rubidium. Mass scanning was achieved by periodic variation of the driving frequency ν . Parameter: $u = \frac{U}{V}$, at $u = 0.164$ ^{85}Rb and ^{87}Rb are fully resolved. b) Mass doublet $^{83}\text{Kr} - \text{C}_6\text{H}_{11}$. Resolving power $m/\Delta m = 6500$ [9].

instruments was investigated at Bonn University [7,8,9]. We studied the influence of geometrical and electrical imperfections giving rise to higher multipole terms in the field. A very long instrument ($l = 6$ m) for high precision mass measurements was built achieving an accuracy of $2 \cdot 10^{-7}$ in determining mass ratios at a resolving power $\frac{m}{\Delta m} = 16\,000$. Very small ones were used in rockets to measure atomic abundances in the high atmosphere. In another experiment we succeeded in separating isotopes in amounts of milligrams using a resonance method to shake single masses out of an intense ion beam guided in the quadrupole.

In recent decades the r.f. quadrupole whether as mass spectrometer or beam guide due to its versatility and technical simplicity has found broad applications in many fields of science and technology. It became a kind of standard instrument and its properties were treated extensively in the literature [10].

The Ion Trap

Already at the very beginning of our thinking about dynamic stabilization of ions we were aware of the possibility using it for trapping ions in a three-dimensional field. We called such a device "Ionenkäfig" [11,12,13]. Nowadays the word "ion trap" is preferred.

The potential configuration in the ion trap has been given in eq. (3). This configuration is generated by an hyperbolically shaped ring and two hyperbolic rotationally symmetric caps as it is shown schematically in Fig. 6a. Fig. 6b gives the view of the first realized trap in 1954.

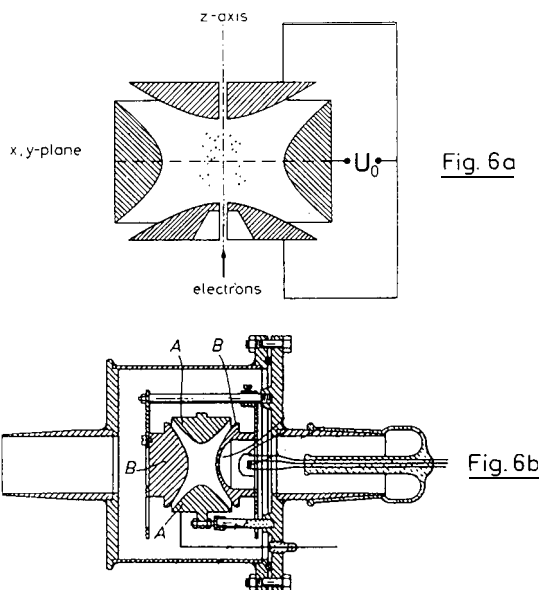

Figure 6. a) Schematic view of the ion trap. b) Cross section of the first trap (1955).

If one brings ions into the trap, which is easily achieved by ionizing inside a low pressure gas by electrons passing through the volume, they perform the same forced motions as in the two-dimensional case. The only difference is that the field in z -direction is stronger by a factor 2. Again a periodic field is needed for the stabilization of the orbits. If the voltage $\Phi_0 = U + V \cos \omega t$ is applied between the caps and the ring electrode the equations of motion are represented by the same Mathieu functions of eq.(5). The relevant parameters for the r motion correspond to those in the x -direction in the plane field case. Only the z parameters are changed by a factor 2.

Accordingly, the region of stability in the a - q -map for the trap has a different shape as is shown in Fig. 7. Again the mass range of the storable ions (i.e. ions in the stable region) can be chosen by the slope of the operation line $a/q = 2U/V$. Starting with operating parameters in the tip of the stable region one can trap ions of a single mass number. By lowering the d.c. voltage one brings the ions near the q -axis where their motions are much more stable.

For many applications it is necessary to know the frequency spectrum of the oscillating ions. From mathematics we learn that the motion of the ions can be described as a slow (secular) oscillation with the fundamental fre-

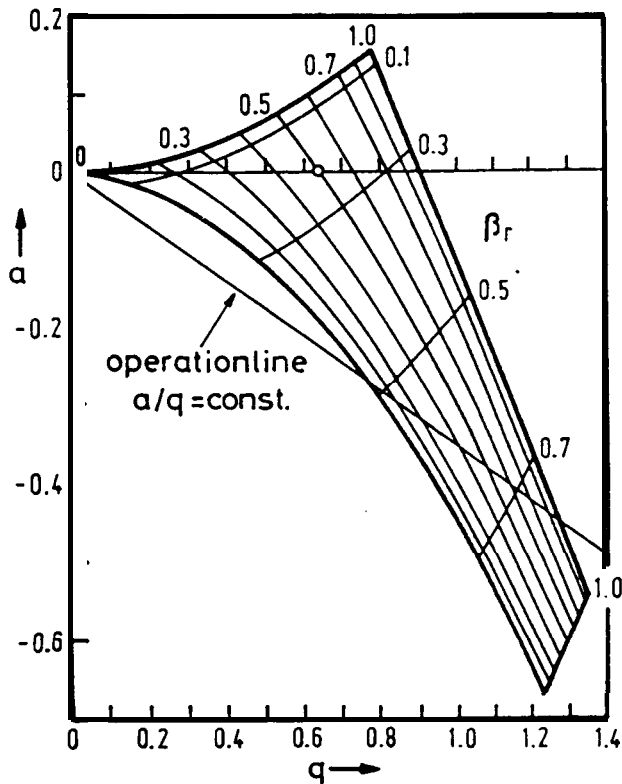

Figure 7. The lowest region for stability in the ion trap. On the lines inside the stability region β_z and β_r , resp. are constant.

quencies $\omega_{r,z} = \beta_{r,z} \cdot \omega/2$ modulated with a micromotion, a much faster oscillation of the driving frequency ω if one neglects higher harmonics. The frequency determining factor β is a function only of the Mathieu parameters a and q and therefore mass dependent. Its value varies between 0 and 1; lines of equal β are drawn in Fig. 7.

Due to the stronger field the frequency ω_z of the secular motion becomes twice ω_r . The ratio ω/ω_z is a criterion for the stability. Ratios of 10: 1 are easily achieved and therefore the displacement by the micromotion averages out over a period of the secular motion.

The dynamic stabilization in the trap can easily be demonstrated in a mechanical analogue device. In the trap the equipotential lines form a saddle surface as is shown in Fig. 8. We have machined such a surface on a round disc. If one puts a small steel ball on it, then it will roll down: its position is unstable. But if one let the disk rotate with the right frequency

Potential in the Ion Trap

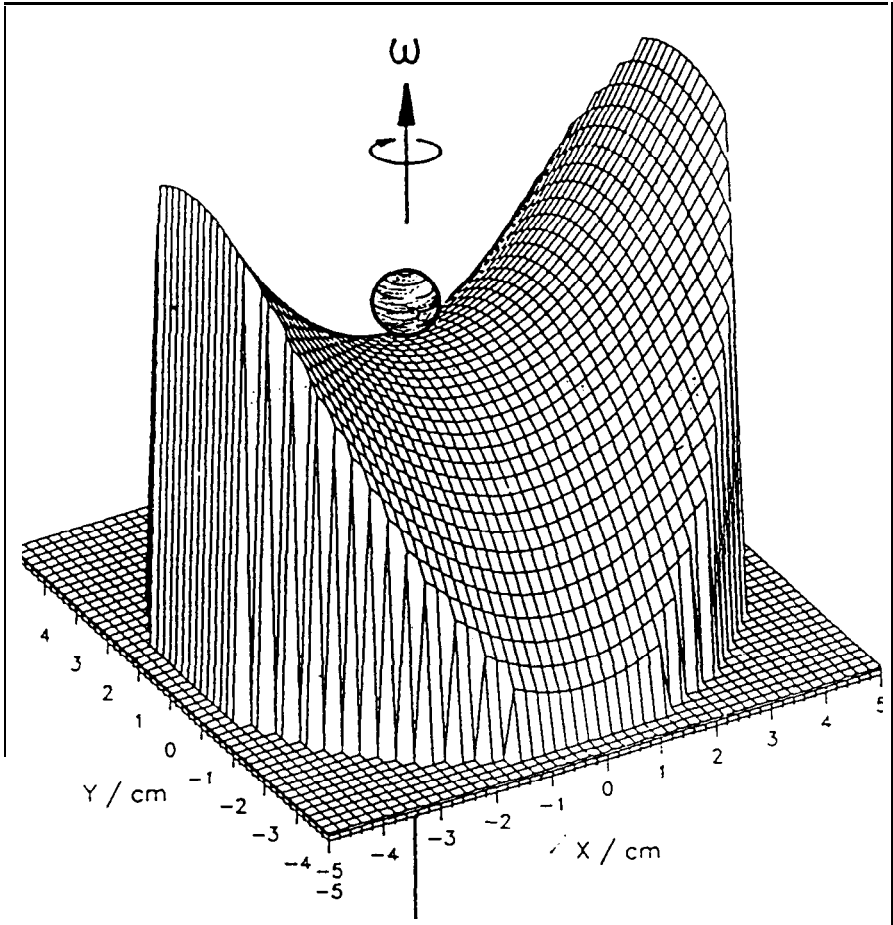

Figure 8. Mechanical analogue model for the ion trap with steelball as "particle"

appropriate to the potential parameters and the mass of the ball (in our case a few turns/s) the ball becomes stable, makes small oscillations and can be kept in position over a long time. Even if one adds a second or a third ball they stay near the center of the disc. The only condition is that the related Mathieu parameter q be in the permitted range. I brought the device with me. It is made out of Plexiglas which allows demonstration of the particle motions with the overhead projector.

This behaviour gives us a hint of the physics of the dynamic stabilization. The ions oscillating in the r - and z -directions to first approximation harmonically, behave as if they are moving in a pseudo potential well quadratic in the coordinates. From their frequencies ω_r and ω_z we can calculate the depth of this well for both directions. It is related to the amplitude V of the driving voltage and to the parameters a and q . Without any d.c. voltage the depth is given by $D_z = (q/8) V$, in the r -direction it is half of this. As in practice V amounts to a few hundred volts the potential depth is of the order of 10 Volts. The width of the well is given by the geometric dimensions. The resulting configuration of the pseudo potential [14] is therefore given by

$$\Phi = D \frac{(r^2 + 4z^2)}{r_0^2 + 2z_0^2}.$$

Cooling process

As mentioned, the depth of the relevant pseudopotential in the trap is of the order of a few volts. Accordingly the permitted kinetic energy of the stored ions is of the same magnitude and the amplitude of the oscillations can reach the geometrical dimensions of the trap. But for many applications one needs particles of much lower energy well concentrated in the center of the trap. Especially for precise spectroscopic measurements it is desirable to have extremely low velocities to get rid of the Doppler effect and an eventual Stark effect, caused by the electric field. It becomes necessary to cool the ions. Relatively rough methods of cooling are the use of a cold buffer gas or the damping of the oscillations by an external electric circuit. The most effective method is the laser induced sideband fluorescence developed by Wineland and Dehmelt [15].

In 1959 Wuerker et al. [16] performed an experiment trapping small charged Aluminium particles ($\phi \sim mm$) in the quadrupole trap. The necessary driving frequency was around 50 Hz accordingly. They studied all the eigenfrequencies and took photographs of the particle orbits; see Figs. 9a, b. After they have damped the motion with a buffer gas they observed that the randomly moving particles arranged themselves in a regular pattern. They formed a crystal.

In recent years one has succeeded in observing optically single trapped ions by laser resonance fluorescence [17]. Walther et al., using a high resolution image intensifier observed the pseudo-crystallization of ions in the trap after cooling the ions with laser light. The ions are moving to such

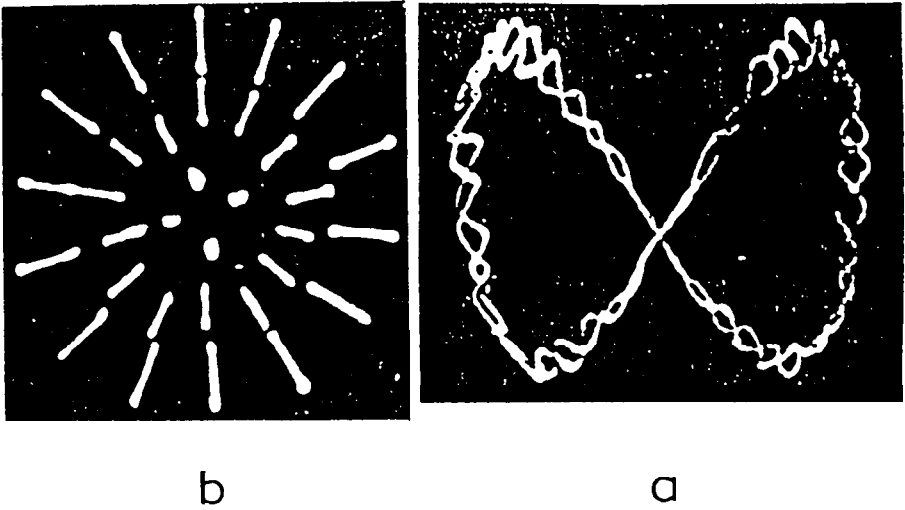

Figure 9. a) Photomicrograph of a Lissajous orbit in the r - z -plane of a single charged particle of Aluminium powder. The micro motion is visible. b) Pattern of "condensed" Al particles [16].

positions where the repulsive Coulomb force is compensated by the focusing forces in the trap and the energy of the ensemble has a minimum. Figs. 10a, b show such a pattern with 7 ions. Their distance is of the order of a few micrometers. These observations opened a new field of research [18].

The Ion Trap as Mass Spectrometer

As mentioned the ions perform oscillations in the trap with frequencies ω_r and ω_z which at fixed field parameters are determined by the mass of the ion. This enables a mass selective detection of the stored ions. If one connects the cap electrodes with an active r.f. circuit with the eigenfrequency Ω , in the case of resonance $\Omega = \omega_r$, the amplitude of the oscillations increases linearly with time. The ions hit the cap or leave the field through a bore hole and can easily be detected by an electron multiplier device. By modulating the ion frequency determining voltage V in a sawtooth mode one brings the ions of the various masses one after the other into resonance, scanning the mass spectrum. Fig. 11 shows the first spectrum of this kind achieved by Rettinghaus [19].

The same effect with a faster increase of the amplitude is achieved if one inserts a small band of instability into the stability diagram. It can be generated by superimposing on the driving voltage $V \cos \omega t$ a small additional rf voltage, e.g. with frequency $\omega/2$, or by adding a higher multipole term to the potential configuration [5b,20].

In summary the ion trap works as ion source and mass spectrometer at the same time. It became the most sensitive mass analyzer available as only a few ions are necessary for detection. Its theory and performance is reviewed in detail by R.E. March [21].

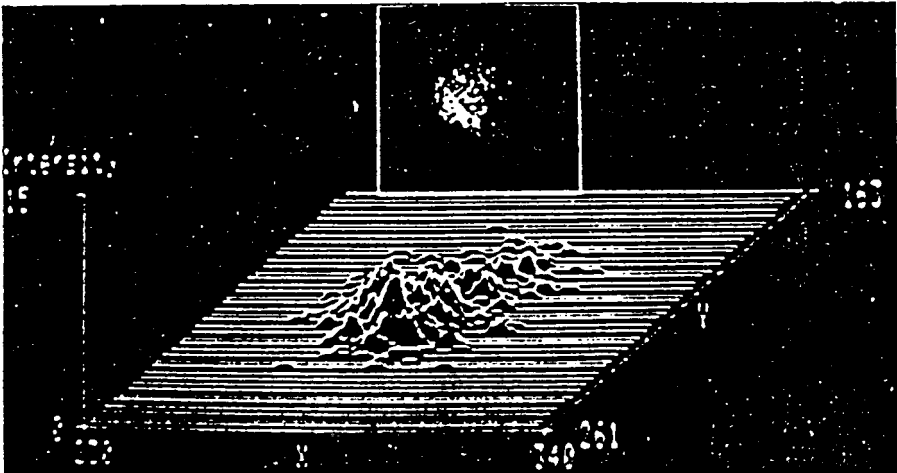
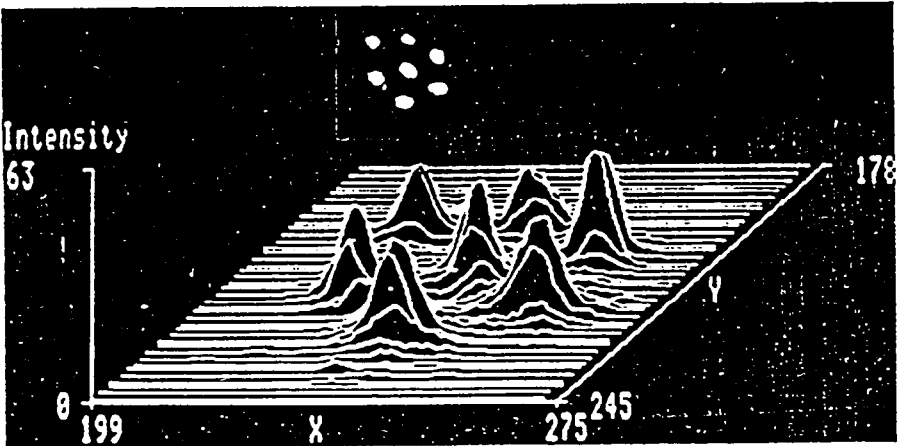

Figure 10. a) Pseudo crystal of 7 magnesium ions. Particle distance $23 \mu\text{m}$. b) The same trapped particles at “higher temperature”. The crystal has melted [18].

The Penning Trap

If one applies to the quadrupole trap only a d.c. voltage in such a polarity that the ions perform stable oscillations in the z -direction with the frequency $\omega_z^2 = \frac{2eU'}{m r_0^2}$ the ions are unstable in the x - y -plane, since the field is directed outwards. Applying a magnetic field in the axial direction, the z -motion remains unchanged but the ions perform a cyclotron motion ω in the x - y -plane. It is generated by the Lorentz force F_L directed towards the center. This force is partially compensated by the radial electric force $F_r = \frac{eU'}{r} r$. As long as the magnetic force is much larger than the electric one, stability exists in the r - y -plane as well. No r.f. field is needed. The resulting rotation frequency calculates to

$$\omega = \omega_c - \frac{\omega_z^2}{2\omega}$$

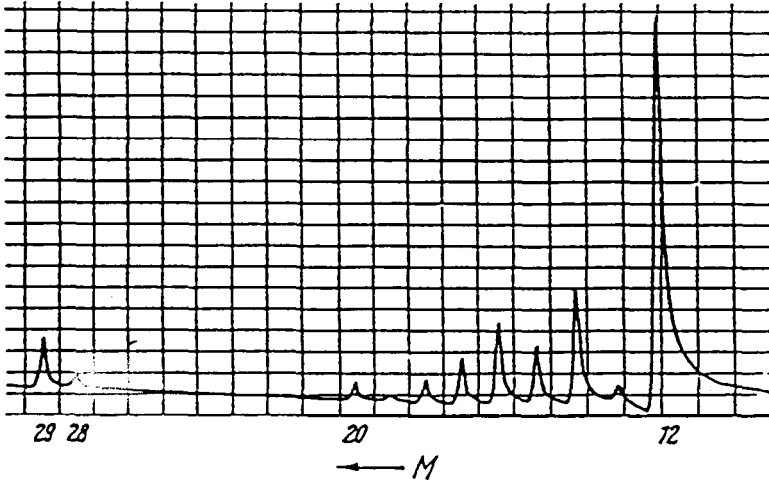

Figure 11. First mass spectrum achieved with the ion trap. Gas: air at $2 \cdot 10^{-9}$ torr [19]

It is slightly smaller than the undisturbed cyclotron frequency eB/m . The difference is due to the magnetron frequency

$$\omega_M = \frac{\omega_z^2}{2\omega}$$

which is independent of the particle mass.

The Penning trap [22], as this device is called, is of advantage if magnetic properties of particles have to be measured, as for example Zeeman transitions in spectroscopic experiments, or cyclotron frequencies for a very precise comparison of masses as are performed e.g. by G. Werth. The most spectacular application the trap has found in the experiments of G. Gräff [23] and H. Dehmelt for measuring the anomalous magnetic moment of the electron. It was brought by Dehmelt [24] to an admirable precision by observing only a single electron stored for many months.

Traps for neutral particles

In the last examination I had to pass as a young man I was asked if it would be possible to confine neutrons in a bottle in order to prove if they are radioactive. This question, at that time only to be answered with "no", pursued me for many years until I could have had replied: Yes, by means of a magnetic bottle. It took 30 years until by the development of superconducting magnets its realization became feasible.

Using the example of such a bottle I would like to demonstrate the principle of confining neutral particles. Again the basis is our early work on focusing neutral atoms and molecules having a dipole moment by means of multipole fields making use of their Zeeman or Stark effect to first and second order [1,2,3]. Both effects can be used for trapping. Until now only magnetic traps were realized for atoms and neutrons. Particularly, B. Martin, U. Trinks, and K. J. Kügler contributed to their development with great enthusiasm.

The principle of magnetic bottles

The potential energy U of a particle with a permanent magnetic moment μ in a magnetic field is given by $U = -\mu B$. If the field is inhomogenous it corresponds to a force $F = grad(\mu B)$. In the case of the neutron with its spin $\hbar/2$ only two spin directions relative to the field are permitted. Therefore, its magnetic moment can be oriented only parallel or antiparallel to B . In the parallel position the particles are drawn into the field and in the opposite orientation they are repelled. This permits their confinement to a volume with magnetic walls.

The appropriate field configuration to bind the particles harmonically is in this case a magnetic sextupole field. As I have pointed out such a field B increases with r^2 , $B = \frac{B_0}{r_0^2} \cdot r^2$ and the gradient $\frac{\delta B}{\delta r}$ with r respectively.

In such a field neutrons with orientation $\mu \uparrow \uparrow B$ satisfy the confining condition as their potential energy $U = + \mu B \sim r^2$ and the restoring force $\mu grad B = -cr$ is always oriented towards the center. They oscillate in the field with the frequency $\omega^2 = \frac{2\mu B_0}{\dots}$. Particles with $\mu \uparrow \downarrow B$ are defocused and leave the field. This is valid only as long as the spin orientation is conserved. Of course, in the sextupole the direction of the magnetic field changes with the azimuth but as long as the particle motion is not too fast the spin follows the field direction adiabatically conserving the magnetic quantum state. This behaviour permits the use of a magnetic field constant in time in contrast to the charged particle in an ion trap.

An ideal linear sextupole in the x - z -plane is generated by six hyperbolically shaped magnetic poles of alternating polarity extended in y -direction, as shown in Figs. 12a, b. It might be approximated by six straight current leads

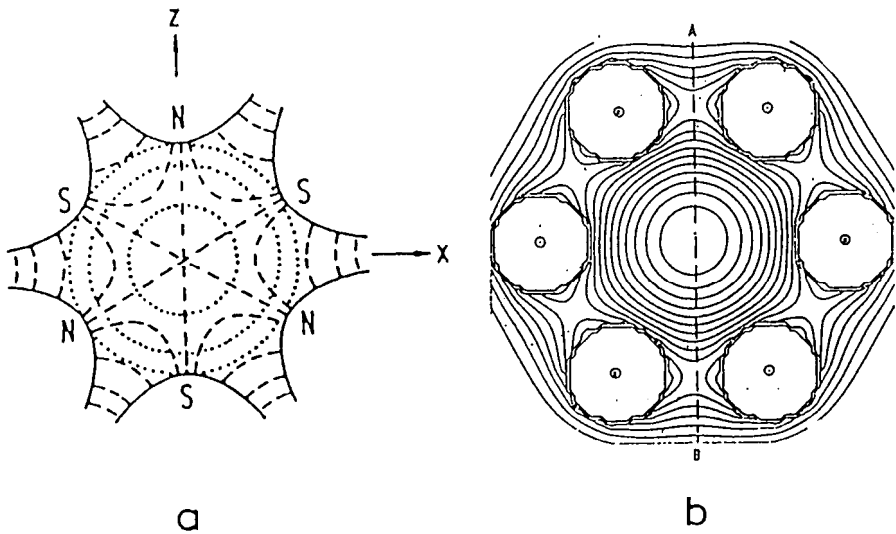

Figure 12. a) Ideal sextupole field. Dashed: magnetic field lines, dotted: lines of equal magnetic potential, $B = \text{const.}$ b) Linear sextupole made of 6 straight current leads with alternating current direction.

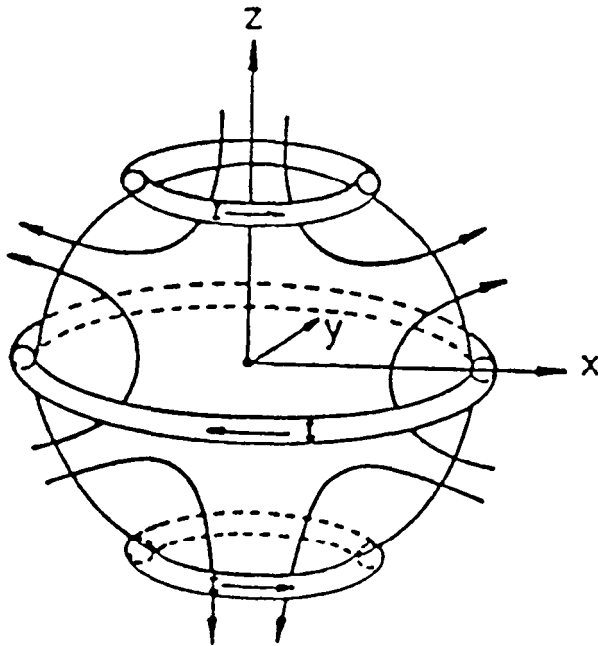

Figure 17. Sextupole sphere

with alternating current directions arranged in a hexagon. Such a configuration works as a lense for particles moving along the y-axis.

There are two possibilities to achieve a closed storage volume: a sextupole sphere and a sextupole torus. We have realized and studied both.

The spherically symmetric field is generated by three ring currents in an arrangement shown in Fig. 13. The field B increases in all directions with r^2 and has its maximum value B_0 at the radius r_0 of the sphere. Using superconducting current leads we achieved $B_0 = 3T$ in a sphere with a radius of 5 cm. But due to the low magnetic moment of the neutron $\mu = 6 \cdot 10^{-8} eV/T$ the potential depth μB_0 is only $1.8 \cdot 10^{-7} eV$ and hence the highest velocity of storable neutrons is only $v_{\max} = 6m/s$. Due to their stronger moment for Na atoms these values are $2.2 \cdot 10^{-4} eV$ and 37 m/s, respectively.

The main problem with such a closed configuration is the filling process, especially the cooling inside. However, in 1975 in a test experiment we succeeded in observing a storage time of 3 s for sodium atoms evaporated inside the bottle with its Helium cooled walls [25]. But the breakthrough in confining atoms was achieved by W. D. Phillip and H.J. Metcalf using the modern technique of Laser cooling [26].

The problem of storing neutrons becomes easier if one uses a linear sextupole field bent to a closed torus with a radius R as is shown in Fig. 14. The magnetic field in the torus volume is unchanged $B = \frac{B_0}{r} \cdot r^2$ and has no component in azimuthal direction. The neutrons move in a circular orbit with radius R if the centrifugal force is compensated by the magnetic force

$$F_c = \frac{mv_\phi^2}{R_S} = \mu \left. \frac{\delta B}{\delta r} \right]_{R_S} .$$

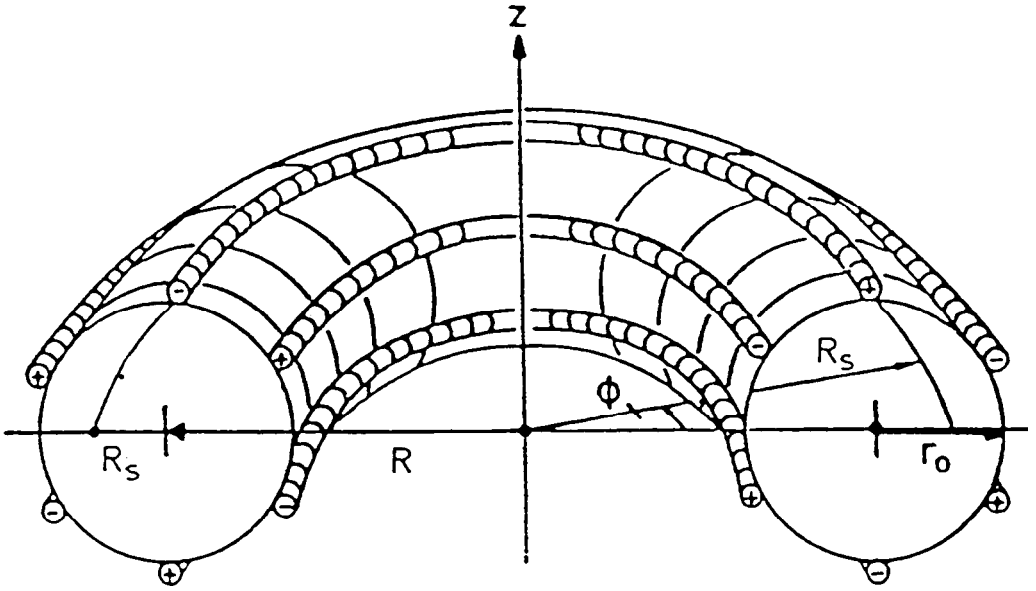

Figure 14. Sextupole torus. R , orbit of circulating neutrons.

In such a ring the permitted neutron energy is limited by

$$E_{max} = \mu \cdot B_0 \left(\frac{R}{r_0} + 1 \right).$$

It is increased by a factor $\left(\frac{R}{r_0} + 1\right)$ compared to the case of the sextupole sphere. As the neutrons have not only an azimuthal velocity but also components in r and z directions they are oscillating around the circular orbit.

But this toroidal configuration has not only the advantage of accepting higher neutron velocities, it also permits an easy injection of the neutrons in the ring from the inside. The neutrons are not only moving in the magnetic potential well but they also experience the centrifugal barrier. Accordingly, one can lower the magnetic wall on the inside by omitting the two inward current leads. The resulting superposition of the magnetic and the centrifugal potential still provides a potential well with its minimum at the beam orbit. But there is no barrier for the inflected neutrons.

It is obvious, that the toroidal trap in principle works analogous to the storage rings for high energy charged particles. In many respects the same problems of instabilities of the particle orbits by resonance phenomena exist, causing the loss of the particles. But also new problems arise like, e.g. undesired spin flips or the influence of the gravitational force. In accelerator physics one has learned to overcome such problems by shaping the magnetic field by employing the proper multipole components. This technique is also appropriate in case of the neutron storage ring. The use of the magnetic force $\mu \cdot \text{grad}B$ instead of the Lorentz force being proportional to B just requires multipole terms of one order higher. Quadrupoles for

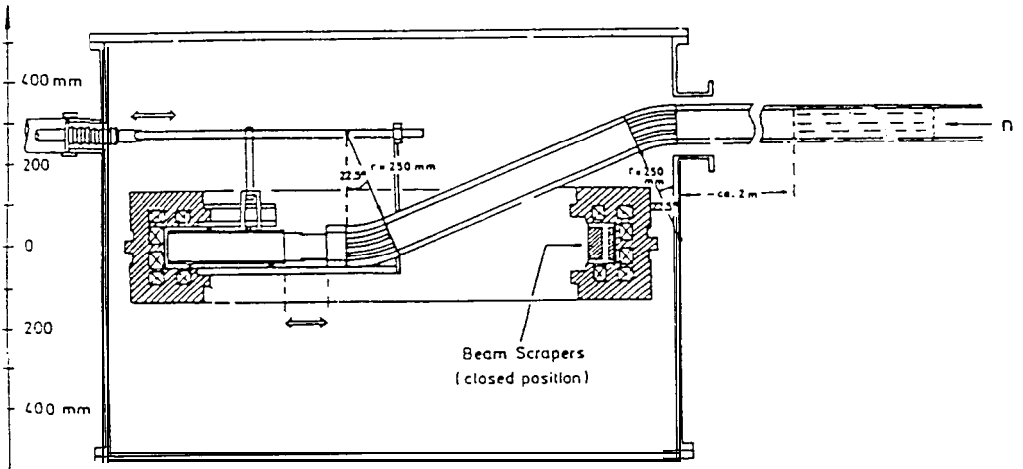
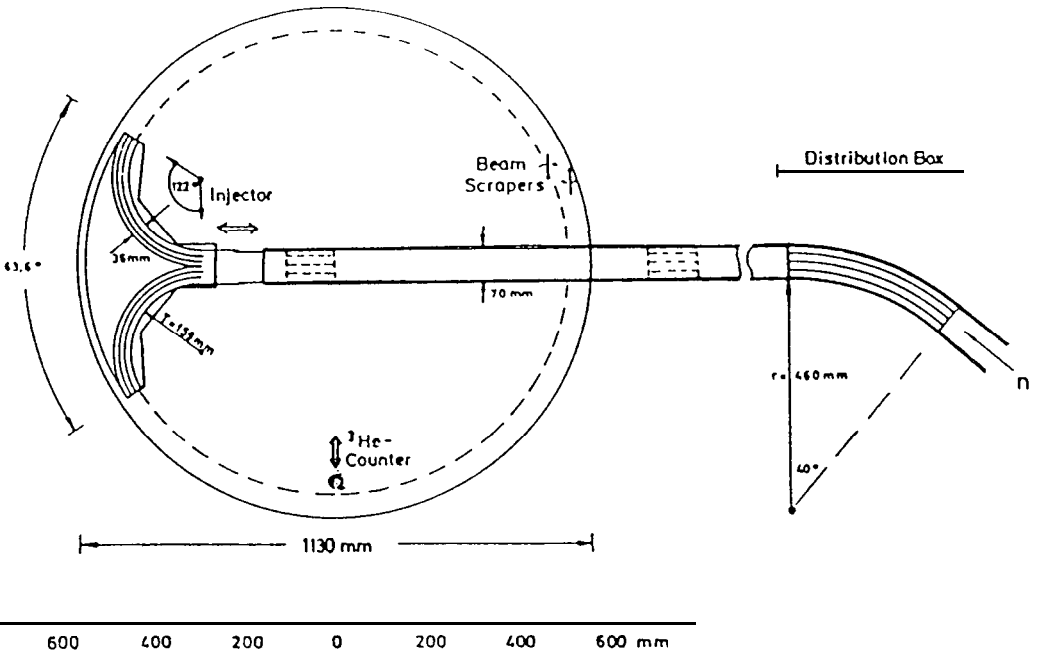

Figure 15. Schematic top and side view of the neutron storage ring experiment.

focusing have to be replaced by sextupoles and e.g. octupoles for stabilization of the orbits by decapoles.

In the seventies we have designed and constructed such a magnetic storage ring with a diameter of the orbits of 1 m. The achieved usable field of 3.5 T permits the confinement of neutrons in the velocity range of 5 - 20 m/s corresponding to a kinetic energy up to $2 \cdot 10^6 eV$. The neutrons are injected tangentially into the ring by a neutron guide with totally reflecting walls. The inflector can be moved mechanically into the storage volume and shortly afterwards be withdrawn.

The experimental set up is shown in Fig. 15. A detailed description of the

storage ring, its theory and performance is given in [27]. In 1978 in a first experiment we have tested the instrument at the Grenoble high flux reactor. We could observe neutrons stored up to 20 min after injection by moving a neutron counter through the confined beam after a preset time. As by the detection process the neutrons are lost, one has to refill the ring starting a new measurement. But due to the relatively low flux of neutrons in the acceptable velocity range, their number was too low to make relevant measurements with it.

In a recent experiment [28] at a new neutron beam with a flux improved by a factor 40 we could observe neutrons up to 90 min, i.e. roughly 6 times the decay time of the neutron due to radioactive decay. Fig. 16 shows the measured profile of the neutron beam circulating inside the magnetic gap. Measuring carefully the number of stored neutrons as a function of time we could determine the lifetime to $\tau = 877 \pm 10$ s (Fig. 17).

The analysis of our measurements lets us conclude that the intrinsic storage time of the ring for neutrons is at least about one day. It shows that we had understood the relevant problems in its design.

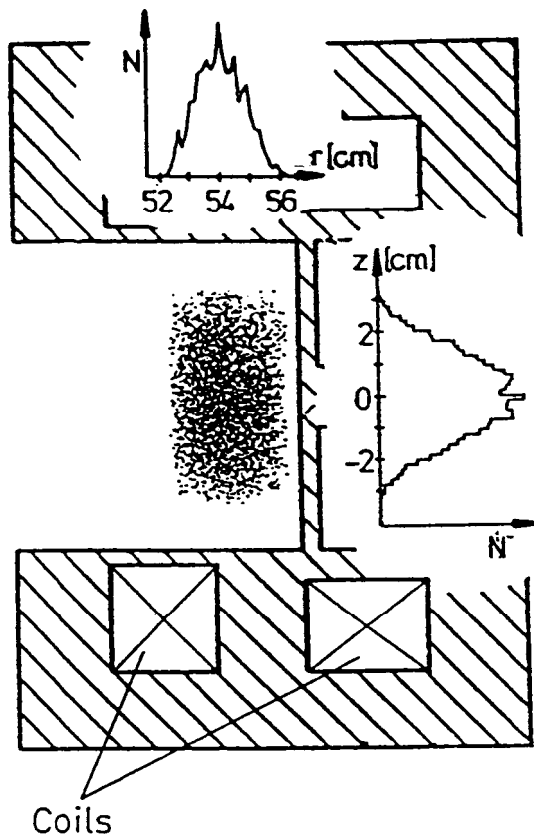

Figure 16. Beam profile of the stored neutrons inside the magnet gap 400 sec after injection.

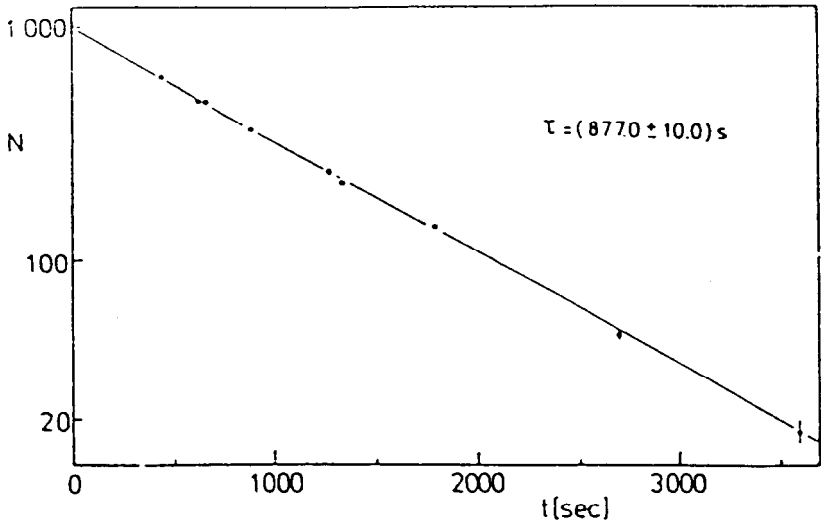

Figure 17. Logarithmic decrease of the number of stored neutrons with time.

The storage ring as a balance

This very reproducible performance permitted another interesting experiment. As I explained the neutrons are elastically bound to the symmetry plane of the magnetic field. Due to their low magnetic moment the restoring force is of the order of the gravitational force. Hence it follows that the weight of the neutron stretches the magnetic spring the particle is hanging on; the equilibrium center of the oscillating neutrons is shifted downwards. The shift z_0 is given by the balance $mg = \mu grad B$. One needs a gradient $\frac{\delta B}{\delta z} = 173 \text{ Gauss/cm}$ for compensating the weight. As the gradient in the ring increases with z and is proportional to the magnetic current Z one calculates the shift z_0 to

$$z_0 = \text{const.} \cdot mg / I.$$

It amounts in our case to $z_0 = 1.2 \text{ mm}$ at the highest magnet current $Z = 200 \text{ A}$ and 4.8 mm at 50 A accordingly.

By moving a thin neutron counter through the storage volume we could measure the profile of the circulating neutron beam and its position in the magnet. Driving alternating the counter downwards and upwards in many measuring runs we determined z_0 as a function of the magnet current.

The result is shown in Fig. 18. The measured data taken with different experimental parameters are following the predicted line. A detailed analysis gives for the gravitational mass of the neutron the value

$$m_g = (1.63 \pm 0.06) \cdot 10^{-24} \text{ g.}$$

It agrees within 4 % with the well known inertial mass.

Thus the magnetic storage ring represents a balance with a sensitivity of 10^{-25} g . It is only achieved because the much higher electric forces play no role at all.

I am convinced that the magnetic bottles developed in our laboratory as described will be useful and fruitful instruments for many other experiments in the future as the Ion Trap has already proved.

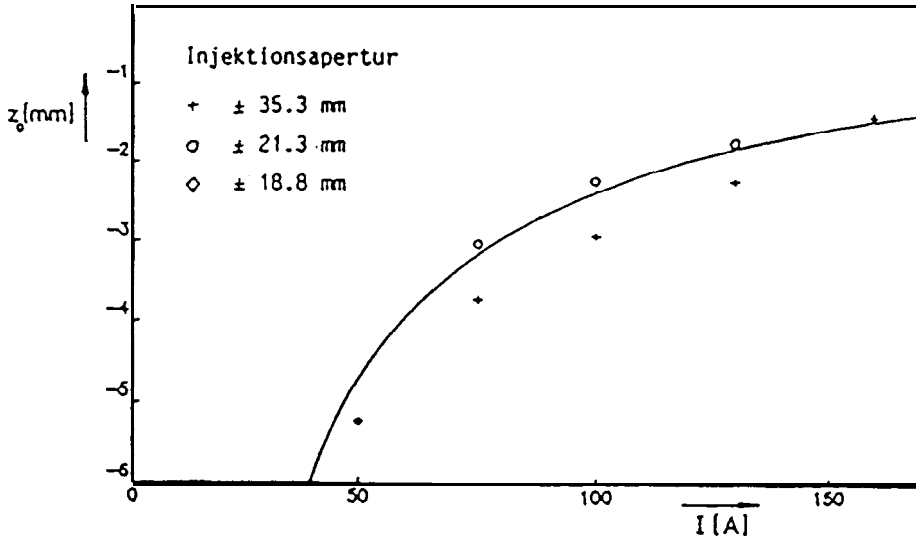

Figure 18. Downward shift of the equilibrium center of the neutron orbits due to the weight of the neutron as function of the magnetic current.

REFERENCES

- [1] H. Friedburg and W. Paul, *Naturwissenschaft* 38, 159 (1951).
- [2] H. G. Bennowitz and W. Paul, *Z. f. Physik* 139,489 (1954).
- [3] H. G. Bennowitz and W. Paul, *Z. f. Physik*, 141, 6 (1955).
- [4] C. H. Townes, *Proc. Nat. Acad. of Science*, 80, 7679 (1983).
- [5] a) W. Paul and H. Steinwedel, *Z. f. Naturforschung* 8a, 448 (1953); b) German Patent Nr. 944 900; USA Patent 2939958.
- [6] W. Paul and M. Raether, *Z. f. Physik*, 140, 262 (1955).
- [7] W. Paul, H. P. Reinhardt, and U. v. Zahn, *Z. f. Physik* 152, 143 (1958).
- [8] F. v. Busch and W. Paul, *Z. f. Physik*, 164, 581 (1961).
- [9] U. v. Zahn, *Z. f. Physik*, 168, 129 (1962).
- [10] P. H. Dawson: *Quadrupole Mass Spectrometry and its Application*, Elsevier, Amsterdam 1976.
- [11] W. Paul, O. Osberghaus, and E. Fischer, *Forsch.Berichte des Wirtschaftsministeriums Nordrhein-Westfalen* Nr. 4 15 (1958).
- [12] K. Berkling, Thesis Bonn 1956.
- [13] E. Fischer, *Zeitschrift f. Physik* 156, 1 (1959).
- [14] H. Dehmelt, *Adv. in Atom and Molec. Phys.*, Vol. 3 (1967).
- [15] D. J. Wineland and H. Dehmelt, *Bull. Am. Phys. Soc.*, 20, 637 (1975).
- [16] R. F. Wuerker and R.V. Langmuir, *Appl. Phys.* 30, 342 (1959).
- [17] W. Neuhauser, M. Hohenstett, P. Toschek and A. Dehmelt, *Phys. Rev. A22*, 1137 (1980).
- [18] F. Dietrich, E. Chen, J. W. Quint and H. Walter, *Phys. Rev. Lett.* 59, 2931 (1987).
- [19] G. Rettinghaus, *Zeitschrift Angew. Physik*, 22, 321 (1967).
- [20] F. v. Busch and W. Paul, *Z. f. Physik*, 165, 580 (1961).
- [21] R. E. March and R. J. Hughes, "*Quadrupole Storage Mass Spectrometry*", -John Wiley, New York 1989.
- [22] F. M. Penning, *Physica* 3, 873 (1936).
- [23] G. Gräff, E. Klempt and G. Werth, *Zeitschrift f. Physik* 222, 201 (1969).
- [24] R. S. van Dyck, P. B. Schwinberg, H. G. Dehmelt, *Phys. Lett.* 38, 310 (1977).
- [25] B. Martin, Thesis Bonn University 1975.
- [26] A. L. Migdal, J. Prodan, W. D. Phillips, Th. H. Bergmann, and H.J. Metcalf, *Phys. Rev. Lett.* 54, 2596 (1985).
- [27] K. J. Kügler, W. Paul, and U. Trinks, *Nucl. Instrument. Methods A* 228, 240 (1985).
- [28] W. Paul, F. Anton, L. Paul, S. Paul, and W. Mampe, *Z. f. Physik C* 45, 25 (1989).